

Contents

- A. Door Panel Alignment and Timing
- B. Mechanical Switch Adjustments
- C. Proximity Switch Adjustments
- D. Door Stops And Cylinder Rod Adjustment
- E. Touchbars
- F. Door Speed Adjustments

A. Door Panel Alignment and Timing

1. Adjust the LH door panel connecting rod length to maintain the panel partially open (one or two inches). Adjust the RH door panel connecting rod length so that clearance between the lock pawl and the cam (part of the teeter lever and cam assembly) is 1/8 to 3/16 inches. See Figure 1. Secure the locknuts while maintaining clevises on opposite ends of the rod parallel to each other. This will permit the self-aligning bearings to allow for linkage rotation.
2. Adjust the LH door panel connecting rod length to bring that door to its closed position, lightly preloaded against the RH door panel.
3. Manually open the doors by pushing out on the door panels. Remove your hand(s) and allow the door panels to close. The doors should close with the LH door panel overlapping the RH door panel. The correct adjustment is obtained when approximately 1/4 inch of clearance exists between the door edge and when the LH door panel just begins to overlap the RH door panel. The LH panel door edge should never be permitted to hit the edge of the RH door panel when closing.
4. Secure the locknuts on the LH door panel connecting rod, noting proper clevis alignment is the same when the RH door panel was done.

NOTE: The connecting rods have right hand threads at the end with 2 jamb nuts and left hand threads at the opposite end.

5. With the RH lever assembly stop screw adjusted inward to allow the RH door to open beyond the 90 degree position, open the RH panel to the 90 degree open position. Turn the stop screw counterclockwise to just make contact with the rear of the lever assembly. Tighten the locknut to maintain this adjustment.
6. With the LH lever assembly stop screw adjusted inward to allow the LH door to open beyond the 90 degree position, open the LH panel to the 90 degree open position. Turn the stop screw counterclockwise to just make contact with the front of the arm assembly. Tighten the locknut to maintain this adjustment.

NOTE: With the LH door panel against the stop screw, the RH panel should not be in contact with its stop screw. With the RH door panel held against its stop screw, the LH panel should not contact its stop screw. If the door panels cannot be opened to a full 90 degree position with the stop screws adjusted, check the cylinder to determine if the piston rod adjustment is causing the rod to bottom prematurely against the rear end cap. Readjust rod length if required. Whenever the arm assembly stop screws are readjusted, the piston rod shaft length adjustment should be rechecked.

7. Adjust the spring by loosening both nuts and check for the proper tension to suit the required door edge closing force - (Approximately 18 pounds). Tighten both nuts when proper tension is achieved.

CAUTION: The cylinder assembly includes a scribe mark around the piston rod shaft to be used as a reference mark for adjusting proper piston position. The piston must never bottom in the cylinder.

8. With the RH door panel held manually against its stop screw, adjust the cylinder's piston rod length so that the piston just bottoms or is within 1/32 inch to 1/16 inch of bottoming in the open position with the arm assemblies, RH and LH, are engaging the stop screws. Where adjustment is required, hold the knurled heavy-duty pliers and loosen the jam nut. Adjust the rod length by adjusting the protruding portion of the piston rod with a pair of length of the rod end bearing. Be sure to tighten the jam nut securely after adjustment.

CAUTION: If the doors are stopped primarily by the piston bottoming against the rear end cap, damage could be done to the cylinder assembly. Check that the doorstops and the cylinder do not prevent the doors from opening full 90°. The cylinder piston must not bottom-out at either open or closed position. This can be determined by either scribing a line on the cylinder rod or by removing the rod end bearing from the teeter cam. Manually holding the doors open or closed and manually extending the cylinder rod will determine amount of remaining stroke. Adjust length as required.

9. The door system air valve must be in the "ON" position. With the door master switch "ON", place the door controller in a rear door open position (or manually actuate the door lock solenoid). Manually hold the RH door panel fully open against the arm assembly stop. Do not hold using the touch bar handle, as this will energize the cylinder magnet valve.
10. Note the location of the cylinder piston rod scribe mark relative to the cylinder end cap face. Actuate the touch bar handle thereby energizing the magnet valve and applying air to the cylinder. There should be a slight displacement of the piston rod into the cylinder (up to, but not exceeding 1/16 inch), verifying that the piston rod was not bottomed in the cylinder.

B. Mechanical Switch Adjustments

If actuator assembly is equipped with electronic proximity switches, proceed to Section C.

1. LS1 Adjustment

The LS1 Switch is typically used to activate the brake interlock circuit. LS1 MUST make and brake with doors locked, while the lock pawl is engaged in cam notch. LS1 switch plunger MUST NOT bottom out. See Figure 1. In the case where LS1 is attached directly to the lock pawl, no adjustment is required. See Figure 2.

Connecting Rod Adjustment

(Cam to Door Lever Rods): Check that the lock pawl-cam notch gap is correct with doors fully closed. Gap should be 1/8" min.- 3/16" max. Adjust connecting rods to achieve. See Figure 1. (Refer to Section A.1)

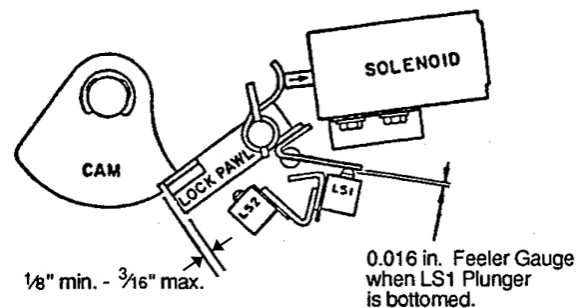

NOTE:
 Adjust Conn. Rods with doors closed to obtain this dimension.

NOTE:
 LS1 Switch must make and break when Lock Pawl is engaged in Cam Notch.

Figure 1

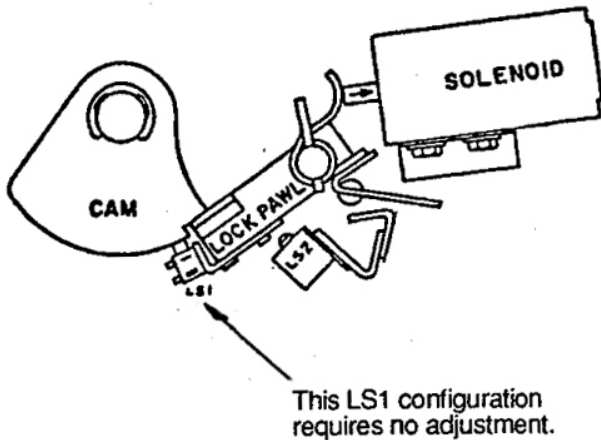

Figure 2

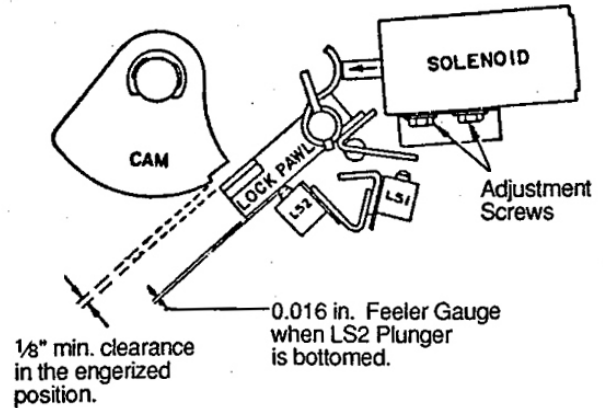

Figure 3

2. **Unlock Solenoid Adjustment**
 Fully actuate the emergency linkage so that the lock pawl falls into and is retained by the emergency cam notch. Position the unlock solenoid so that the lock pawl is released by the emergency cam when the solenoid is energized. (If LS2 bottoms out and prevents the lock pawl from moving far enough, temporarily readjust LS2.) With solenoid energized, min. gap 1/8" must exist between lock pawl and major diameter of cam. See Figure 3. Adjust as required.
3. **LS2 Adjustment:** The LS2 Switch is typically used to control the touchbar circuit. LS2 MUST make and brake with doors unlocked, between the fully unlocked, (solenoid energized position) and the major diameter of the cam. LS2 Switch plunger MUST NOT bottom out. See Figure 3 for details. Adjust as required.

Emergency Release Mechanism:

Slowly operate the emergency release from its normal position to fully unlocked position. Check that the lock pawl DOES NOT bottom out LS2. If necessary, readjust the unlock solenoid then repeat steps 2 and 3.

4. **LS3 Adjustment:** The LS3 Switch is used to break or open the touchbar circuit allowing the doors to close once the doors have reached the full open position. Check that LS3 actuates approx. 80-85 of full open position. LS3 must not bottom out. Adjust as required. See Figure 4.

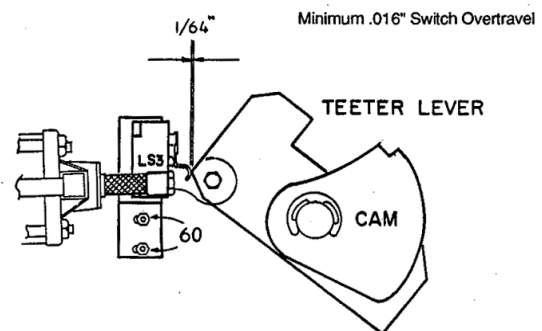

Figure 4

C. Proximity Switch Adjustments

All base plate adjustments are performed at the factory before shipment. If any adjustments are necessary, refer to the following procedure.

1. **LS1 Adjustment:** Check that axial play of the lock pawl is between .015 and .030. If necessary add or remove spacers P/N 96510031-19. Adjust gap between prox. sensor and vane to .060 using feeler gage See Figure 5. Power up sensor. Sensor LED light should be on. Place .0625 spacer between the teeter lever in locked position and lock pawl. Sensor LED light should stay "ON". Place .125" spacer between the teeter lever in locked position and lock pawl. Sensor LED lights should turn "OFF" with the lock pawl still in locked position. If necessary readjust gap between prox. sensor and vane to achieve de-actuation of the prox. sensor when lock pawl is between .0625 and .125 away from the teeter lever See Figure 5. Remove spacer. Secure this adjustment, torque sensor mounting hardware to 130 inch-lbs and witness mark. Torque down bracket's mounting hardware to 7 Ft.-Lbs. and witness mark.

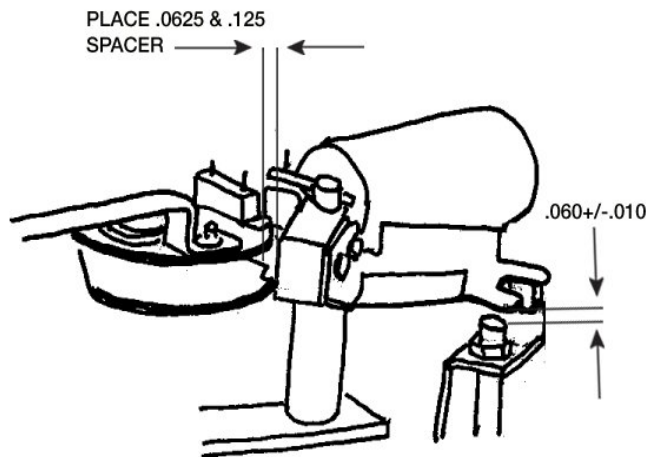

Figure 5

2. **Solenoid Adjustment:** Fully actuate the emergency linkage so that the lock pawl falls into and is retained by the emergency cam notch. Position the unlock solenoid so that the lock pawl is released by the emergency cam when the solenoid is energized. A minimum of .25" clearance must exist between the lock pawl and the major diameter of the teeter cam when the solenoid is in the energized position. See Figure 6. Return emergency handle to un-actuated position and ensure that with lock pawl in locked position and solenoid de-energized, there is a .125 - .188 gap between the lock pawl and solenoid plunger See Figure 7.

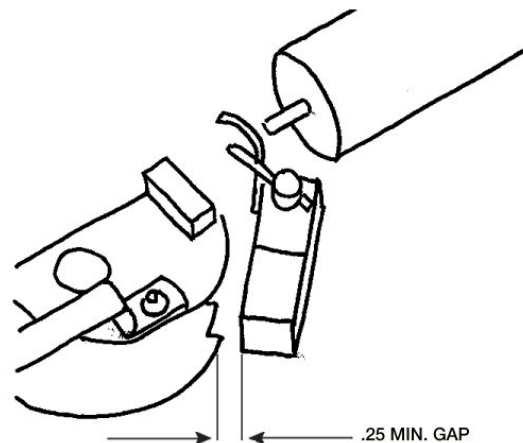

Figure 6

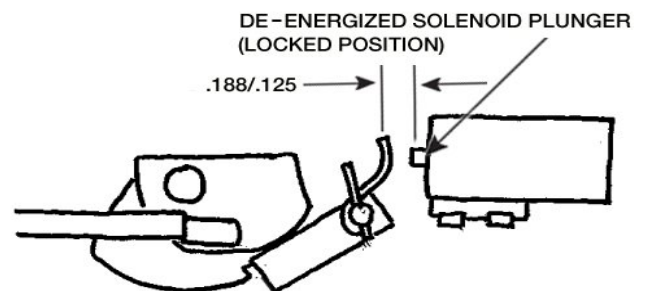

Figure 7

3. **LS2 Adjustment:** Adjust gap between prox. Sensor and vane to $.060+00/-0.010$. Power up sensor. Sensor LED light should be off. With the lock solenoid plunger in unlock (energized) position, adjust LS2 by moving sensor to the position where sensor LED light just turns "ON". De-energized unlock solenoid and let lock pawl to rest against teeter lever cam. Sensor LED light should turn "OFF". Secure this adjustment and witness mark.

4. **Emergency Handle Assembly:** Slowly operate the emergency handle from its normal position to its fully displaced position. Check that the lock pawl actuates the switch. If necessary, readjust position of LS5 switch.

5. **LS3 Adjustment:** Rotate the teeter lever counter clockwise to place teeter lever tab below LS3 proximity sensor. Adjust gap between sensor and bracket to $.125+/-0.005$ See Figure 8. Power up prox. Sensor. Slowly rotate teeter lever clockwise, away from the fully open position. Observe sensor's LED light. It should turn off. Rotate teeter lever counter clockwise to approx. 85 deg. from closed position and adjust LS3 sensor bracket, so proximity sensor just actuates. Secure this adjustment. Torque down lock nuts to 7 FT.-Lbs and witness mark.

6. **LS4 Adjustment (If Equipped):** With the teeter lever in closed position, adjust gap between prox. Sensor and vane to $.125 +/- .005$ See Fig. 8. Power up prox. sensor. LED light should turn "ON" when sensor is above the teeter lever tab. Rotate teeter lever 5 – 10 deg. counter clockwise. Sensor LED light should turn "OFF". Secure this adjustment and witness mark.

7. **LS5 Adjustment (If Equipped):** Slowly operate the emergency handle from its normal position to its fully displaced position. Check that LS5 does not make contact with the lock pawl until the lock pawl falls into the Emergency cam notch. See Figure 9.

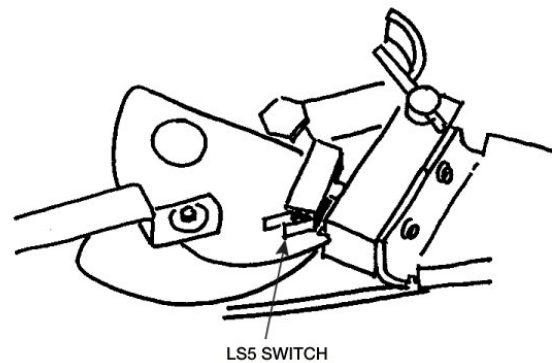

Figure 9

8. Verify through entire stroke of cylinder that no interference exists among moving and stationary parts.

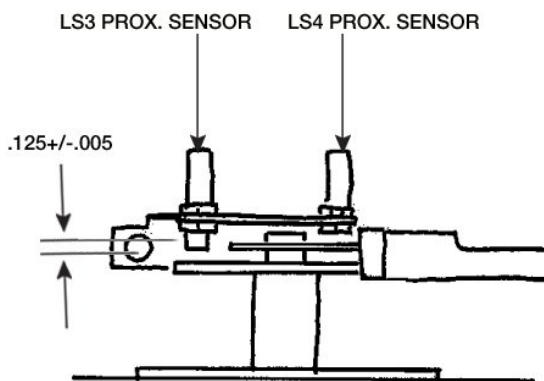

Figure 8

D. Door Stops And Cylinder Rod Adjustment

Check that the doorstops do not prevent doors from opening full 90°. Check that cylinder does not prevent doors from opening full 90°. Cylinder piston must not bottom out at either open or closed position. This can be determined by either scribing a line on the cylinder rod or by removing the rod end bearing from the teeter cam. Manually holding the doors

open or closed and manually extending the cylinder rod will determine amount of remaining stroke. Adjust length as required.

E. Touchbars

Each touchbar has (2) two switches, top and bottom. Check each touchbar for proper actuation in 4 places along the length of the touchbar. Bottom of touchbar tubes **MUST NOT** drag or contact lower bracket. Repair as required. Refer to Bulletin #0030 for adjustment and overhaul instruction.

F. Door Speed Adjustments

NOTE: Adjust the door closing speed first. This adjustment affects the door opening speed.

The Vapor door cylinder has integrated speed controls. Door speeds should be set to allow the doors to open and close smoothly. Repetitive slamming will be detrimental to the service life of this equipment. The opening speed control fitting is located at inlet side of the solenoid mag valve. The closing speed control is located in the cylinder rod end cap.

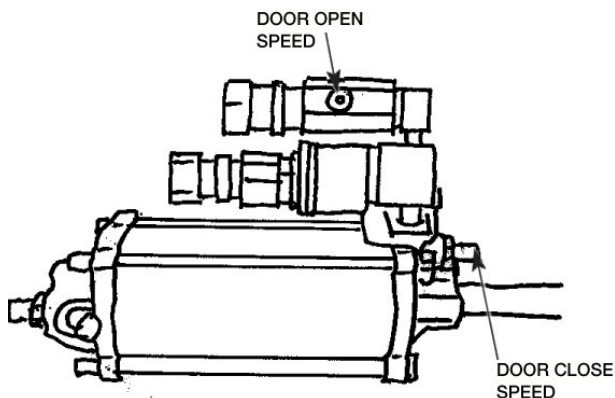

Figure 10

Door Speed Adjustment (For Doors Equipped with an Air Hold Close System)

1. To adjust door closing speed (the control valve is located on the solenoid valve assembly) loosen the locknut and turn the knob clockwise to decrease the door speed, counterclockwise to increase the speed. See Figure 11.

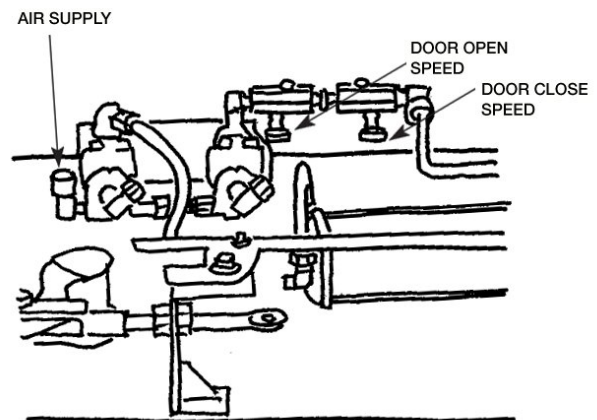

Figure 11

2. To adjust the door opening speed, loosen the locknut and turn the knob clockwise to decrease the speed, counterclockwise to increase the speed.

Components-Hardware: Check that all components are secured with correct hardware and tightened properly. All jam nuts must be tight. There should be no excessive play or excessive friction between any moving parts, door shaft levers and bearings, lower pivot bearings, rod end bearings, cam, lock pawl, cylinder, etc. Repair as required.

