

Preliminary

1. Familiarize yourself with the locations of the locknuts, connecting rods, spherical rod end bearings, closing speed, opening speed and cushioning adjustments. See Photo A.
2. Prior to making any adjustments, check the air pressure gauge – it should read a minimum of 90 psi.
3. **CAUTION:** Remove all the tools and keep hands away from all moving parts. Exhaust the door engine by opening the manual air valve. Doors can then be manually opened.

Recommended Tools

- Open-end wrench set
- Ratchet and socket set
- 5/32" Allen wrench
- Screwdriver
- Feeler gauge

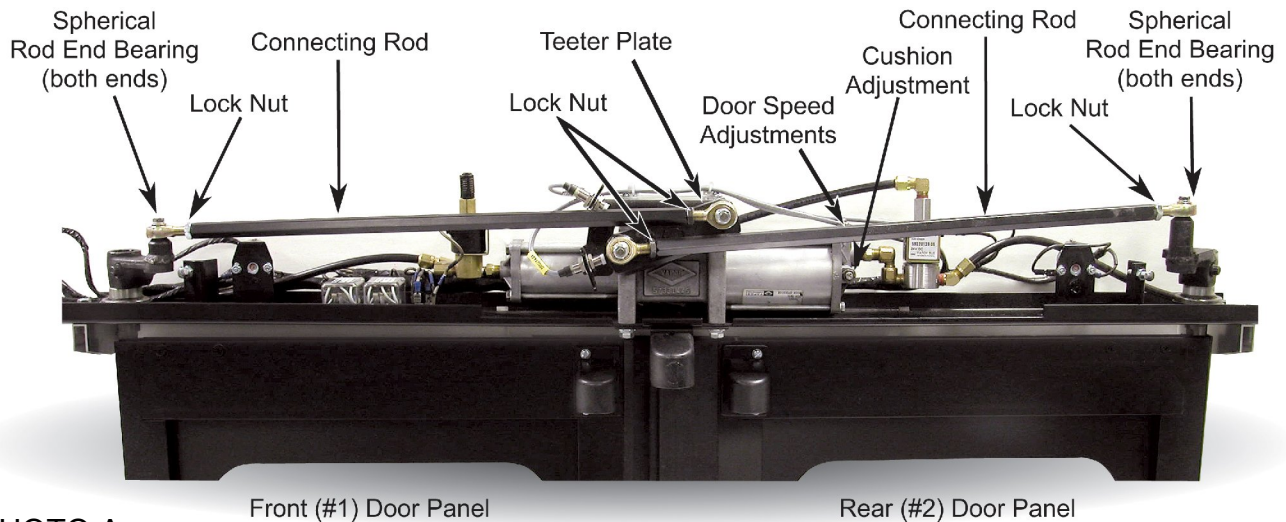

PHOTO A

Mechanical Adjustments

1. Loosen lock nuts on both ends of each connecting rod.
2. Disconnect the connecting rods from the teeter plate.



3. Make sure the connecting rods are clear of the teeter plate – **Keep Hands and Tools Away From All Moving Parts.** CLOSE the manual air valve – the teeter plate will move to the door closed position with the door controller set to the door closed position.



4. Close the rear (#2) door panel. While pushing the door panel closed, grasp the rear door spherical rod end (at the teeter plate) to prevent it from turning and turn the connecting rod until the rod end can slip onto the pin on the teeter plate. Install washer and lightly tighten nut.



5. Close the front (#1) door panel. While pushing the door panel closed, grasp the front door spherical rod end to prevent it from turning and turn the connecting rod until the rod end can slip onto the pin on the teeter plate. Install washer and lightly tighten nut.

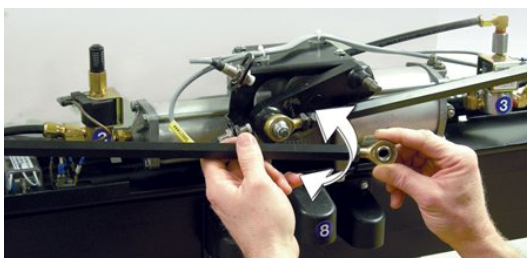

Pre-load Adjustment

This adjustment is necessary for providing the assurance of having tightly sealed doors. Pre-loading will also eliminate rattling at high speed.

1. With connecting rods in position after paragraph 4 and 5, it will be necessary to shorten each connecting rod by rotating the rods a maximum of two (2) turns each. When turning, observe and make sure that the door panels are moving outwardly at the trailing edge and tightening against the door post seal.
NOTE: Make sure that pre-load does not prevent door engine from reaching its full closed position.

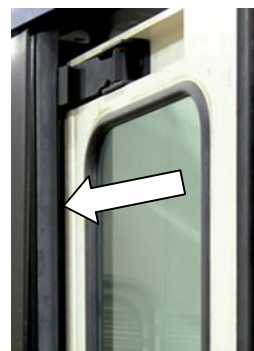

Before



After

2. Check for proper closing by first opening the doors and then closing. Observe the leading edges when meeting at the center. Rear (#2) door panel should lead the front (#1) door panel when closing. If the rear (#2) door panel does not lead, lengthen the front door panel connecting rod until the rear door panel leads with no butting or touching as the edges overlap at the center.

Correct Door Panel Closure

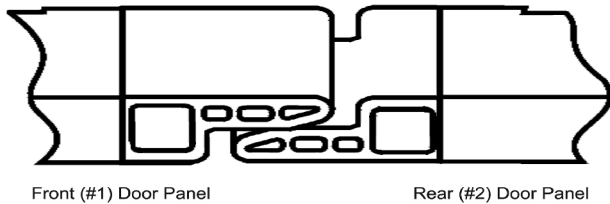

Incorrect Door Panel Closure

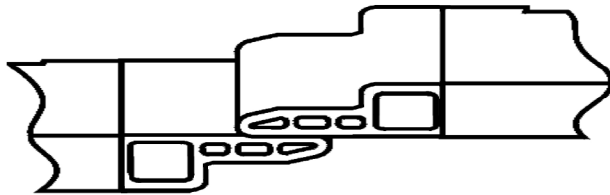

3. **CAUTION:** If the connecting rods are correctly adjusted, the teeter plate should be approximately 15° from the fully closed position. It is extremely important that preloading should not prevent the piston from bottoming against the center casting. The extra rotation will take up all the clearances in the linkage. In no case should the adjustment be made where the piston does not bottom in the door close position.
4. Open the doors and make certain that they press against the door jamb before engine pistons bottoms.

Final Adjustments

1. Before locking down, observe spherical rod end bearings. They should be aligned at 90° on their pins and rock freely to utilize their self-alignment feature.

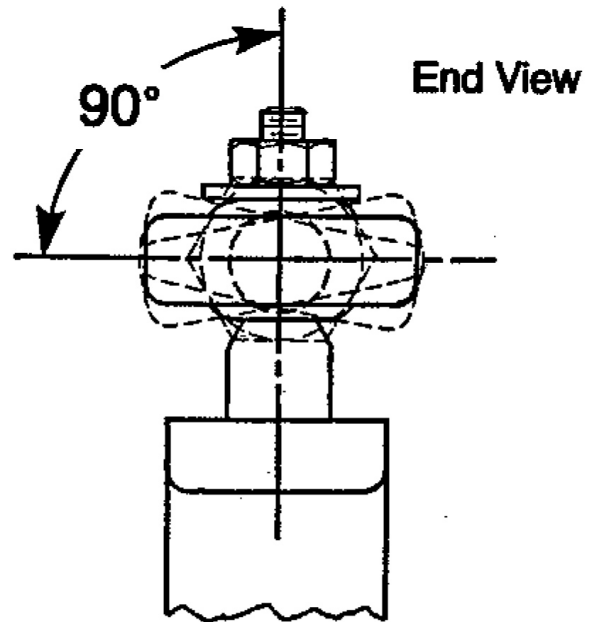

2. With the above aligned, firmly tighten the lock nuts against the connecting rod surface at each end.

Door Speed Adjustments

WARNING: Speed and cushion adjustment screws are not captive and may become projectiles if adjusted too far counterclockwise under air pressure.

Always adjust Closing Speed first: Loosen the jam nut (1) and use the Allen wrench. Clockwise to decrease speed – counterclockwise to increase speed.

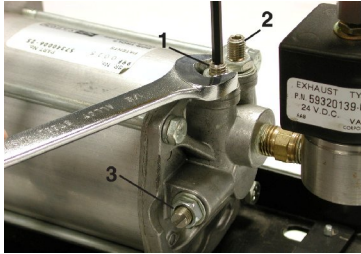

Second: Adjust the opening speed. Loosen the jam nut (2) clockwise to decrease opening speed. Disregard slamming against jamb.

Last: Adjust the cushioning screw to eliminate door opening slamming. Loosen the jam nut (3) and turn screw clockwise for more cushioning. If necessary, readjust opening speed after adjusting the cushion screw.

NOTE: To make door speed adjustments on Vapor Activair engine, see Vapor Bulletin #1002.

Electrical Adjustment

If mechanical switches are used, they will actuate in either the door closed or door open positions by the cam lobes on the teeter plate. Loosen the switch mounting screws to position the switch for proper actuation.

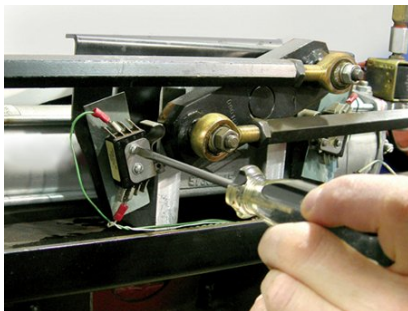

Proper adjustment must provide for a minimum of .015" of over-travel after actuation (over-travel is the movement allowed in the switch after actuation before the switch lever and plunger bottoms).



Use the feeler gauge to adjust for proper over-travel. Tighten the switch mounting screws. Cycle the door engine to verify that the switches actuate and de-actuate properly.

Alternate Mechanical Switch Configuration

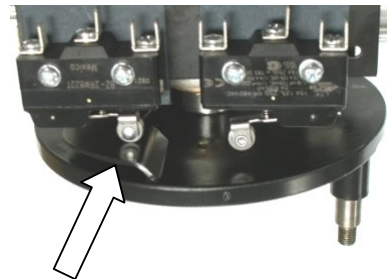

Door Closed Switch to Actuate <math><5^\circ</math> from Full Closed Position



Door Open Switch to Actuate <math><5^\circ</math> from Full Open Position

Switch over-travel is controlled by the switch bracket in this configuration. The switch actuation point is adjusted by moving each switch laterally to get required actuation point as shown above.

For technical assistance:
West – 209-603-5189 John Condon
Central – 847-226-8102 Peter Buckley
East – 847-224-5087 Mike O’Neill

