

# Adjustment Procedures: The Vapor Conventional and the Activair® Differential Engines

This bulletin provides a side-by-side presentation of the adjustment procedures for the Vapor Conventional and Activair Differential Door Engines as used on Slide-Glide Door Applications

## Conventional Differential Engine

### Recommended Tools

- 1/2", 5/8" and 11/16" open end wrenches
- Ratchet and 7/16 socket
- 5/32" Allen wrench
- Flat Screwdriver
- Feeler gauge set

### A. Preliminary

1. Familiarize yourself with the locations of the locknuts, connecting rods, spherical rod end bearings, closing speed, opening speed and cushioning adjustments. See Photo A.
2. Prior to making any adjustments, check the air pressure gauge – it should read a minimum of 90 PSIG.
3. **CAUTION:** Remove all the tools and keep hands away from all moving parts. Exhaust air from the door engine by opening the manual air valve. Doors can then be manually opened.

### Differences Between Differential Engine Types

#### CONVENTIONAL DIFFERENTIAL ENGINE

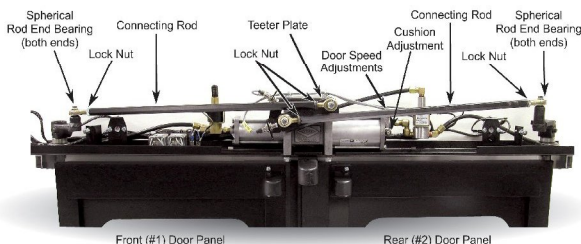

Front (#1) Door Panel      Rear (#2) Door Panel

**PHOTO A**  
**Door System Overview**

## Activair Differential Engine

### Recommended Tools

- 5/8" and 11/16" open end wrenches
- Ratchet and 7/16" and 1/2" sockets
- Feeler gauge set

### A. Preliminary

1. Familiarize yourself with the locations of the locknuts, connecting rods, spherical rod end bearings, closing speed, opening speed and cushioning adjustments. See Photo A.
2. Prior to making any adjustments, check the air pressure gauge – it should read a minimum of 90 PSIG.
3. **CAUTION:** Remove all the tools and keep hands away from all moving parts. Exhaust air from the door engine by opening the manual air valve. Doors can then be manually opened.

### Differences Between Differential Engine Types

#### ACTIVAIR DIFFERENTIAL ENGINE

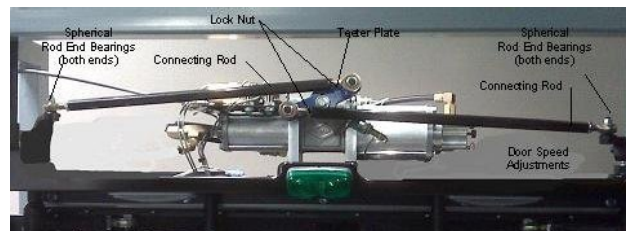

**PHOTO A**  
**Door System Overview**

## Adjustment Procedures: The Vapor Conventional and the Activair® Differential Engines

### A. Door Speed Adjustment Controls

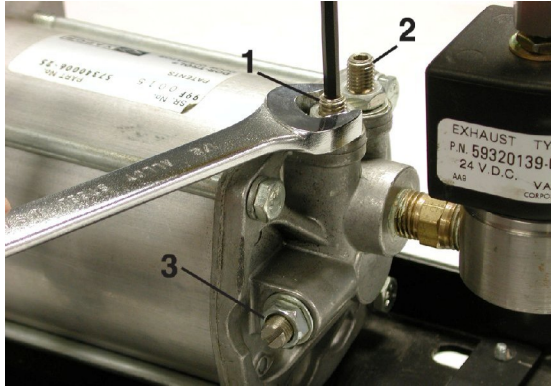

1. Door Closing Speed
2. Door Open Speed
3. Door Open Cushion

**PHOTO B**

#### Conventional Differential Engine Speed Controls

**WARNING:** Speed and cushion adjustment screws are not captive and may become projectiles if adjusted too far counterclockwise with air pressure applied to the door engine.

1. Open (2) and closing speed (1) screws independently adjust their respective speeds. Cushion speed (3) when adjusted properly provides deceleration upon opening of the doors to prevent slamming. The Point at which the deceleration due to the cushion controls begins is fixed on the Conventional Vapor Differential Engine
2. Speed adjustments are accomplished by unlocking the ½" jamb nut and turning the speed adjustment screws with a 5/32" hex key. Cushion adjustment is accomplished by unlocking the ½" jamb nut and turning the cushion adjustment with a flat screwdriver.

### A. Door Speed Adjustment Controls

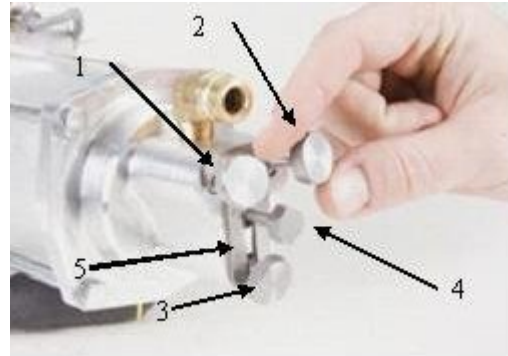

1. Door Closing Speed
2. Door Open Speed
3. Door Open Cushion
4. Cushion Onset Adjustment
5. Retaining Plate Keeps Screws "captive"

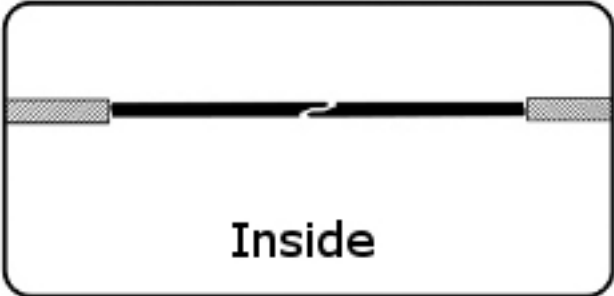
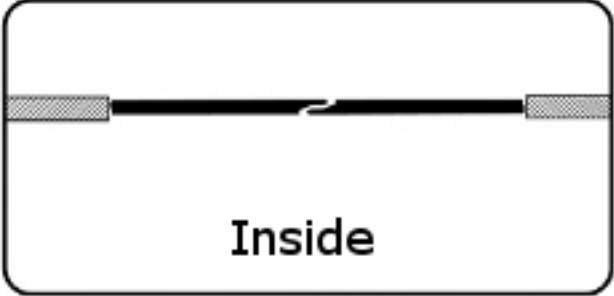
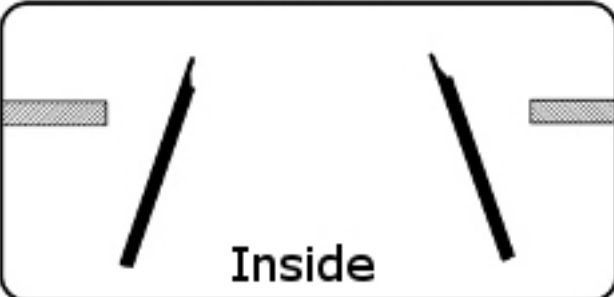
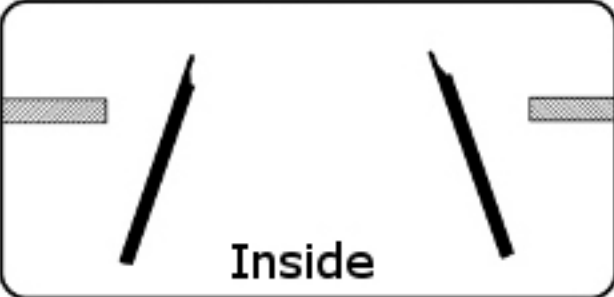

**PHOTO B**

#### ActivAir Differential Engine Speed Controls

**WARNING:** Do not remove retainer plate (5) or speed, cushion and cushion onset adjustment screws become non-captive and may become projectiles if adjusted too far counterclockwise with air pressure applied to the door engine.

1. Open (2) and closing (1) speed screws independently adjust their respective speeds. Cushion speed (3) when adjusted properly provides deceleration upon opening of the doors to prevent slamming. The point at which the deceleration due to the cushion control begins is adjustable on the Activair Vapor Differential Engine (4) providing a means to optimize the door opening speed for a range of door opening widths, allowing the fastest opening speed while still eliminating slamming during the opening cycle.
2. **Speed adjustments are made without tools** by turning the thumb screws. Cushion onset is adjusted with the use of a 1/2" socket.
3. The Activair Vapor Differential Engine also provides an adjustment screw retainer (5) that holds the adjustment screws "captive" as long as it remains securely in place.

## Adjustment Procedures: The Vapor Conventional and the Activair® Differential Engines

<p><b>Closed Position</b></p>  <p><b>Inside</b></p>	<p><b>Closed Position</b></p>  <p><b>Inside</b></p>
<p><b>Cushion Onset Point</b></p>  <p><b>Inside</b></p>	<p><b>Cushion Onset Point</b></p>  <p><b>Inside</b></p>
<p><b>Door Open</b></p>  <p><b>Inside</b></p>	<p><b>Door Open</b></p>  <p><b>Inside</b></p>
<p>The Vapor Conventional Differential Door engine provides one fixed cushion onset point at which door opening deceleration begins.</p>	<p>The Vapor ActivAir Door engine provides an <b>adjustable cushion onset position</b> allowing optimum combination of door open deceleration and opening speed for a wide range of door sizes.</p>

## Adjustment Procedures: The Vapor Conventional and the Activair® Differential Engines

### B. Mechanical Adjustments

1. Loosen lock nuts on both ends of each connecting rod.



2. Disconnect the connecting rods from the teeter plate.

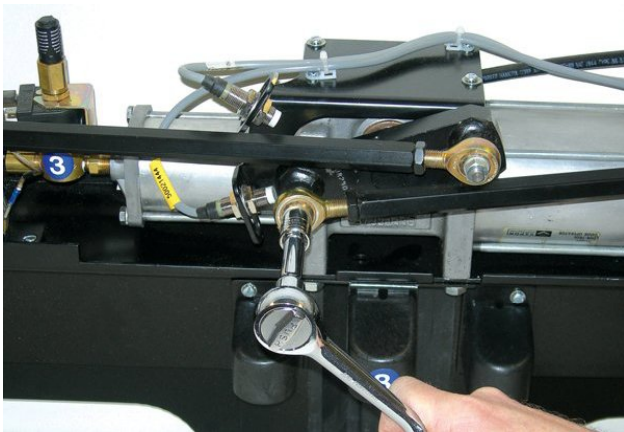

3. Make sure the connecting rods are clear of the teeter plate – **Keep Hands and Tools Away From All Moving Parts**. CLOSE the manual air valve and the teeter lever will move to the door closed position with the door controller set to the door closed position.

### B. Mechanical Adjustments

1. Loosen lock nuts on both ends of each connecting rod.



2. Disconnect the connecting rods from the teeter plate.

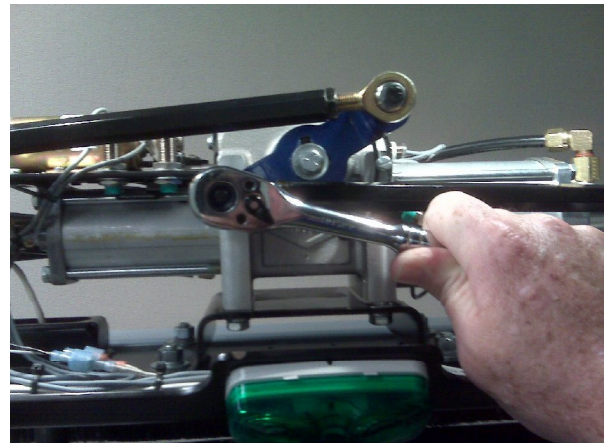

3. Make sure the connecting rods are clear of the teeter plate – **Keep Hands and Tools Away From All Moving Parts**. CLOSE the manual air valve and the teeter lever will move to the door closed position with the door controller set to the door closed position.

**Important** The Door Closed Sensor is preset during manufacture and the door adjustments must be performed using the fully closed position of the door engine as the starting point to ensure valid door closed indication.

## Adjustment Procedures: The Vapor Conventional and the Activair® Differential Engines



4. Close the rear (#2) door panel. While pushing the door panel closed, grasp the rear door spherical rod end (at the teeter plate) to prevent it from rotating and turn the connecting rod until the rod end can slip onto the pin on the teeter plate. Install washer and lightly tighten nut.



5. Close the front (#1) door panel. While pushing the door panel closed, grasp the front door spherical rod end to prevent it from rotating and turn the connecting rod until the rod end can slip onto the pin on the teeter plate. Install washer and lightly tighten nut.



4. Close the rear (#2) door panel. While pushing the door panel closed, grasp the rear door spherical rod end (at the teeter plate) to prevent it from rotating and turn the connecting rod until the rod end can slip onto the pin on the teeter plate. Install washer and lightly tighten nut.



5. Close the front (#1) door panel. While pushing the door panel closed, grasp the front door spherical rod end to prevent it from rotating and turn the connecting rod until the rod end can slip onto the pin on the teeter plate. Install washer and lightly tighten nut.

## Adjustment Procedures: The Vapor Conventional and the Activair® Differential Engines



### C. Preloading Adjustment

This adjustment is necessary to assure tightly sealed doors. Preloading will also eliminate door rattling at high vehicle speeds.

1. With connecting rods in position after paragraphs B4 and B5, it is necessary to shorten each connecting rod by rotating each rod a maximum of two (2) turns. When turning, observe and make sure that the door panels are moving outwardly at the trailing edge and tightening against the door post seal.



**NOTE:** Make sure that Preload does not prevent the door engine from reaching its full closed position. Proper preload will produce a door that is firmly closed against the jamb seals and is resistant to moderate pulling on the trailing edge while providing a firm open position for use as a hand hold support by an entering or exiting passenger.



### C. Preloading Adjustment

This adjustment is necessary to assure tightly sealed doors. Preloading will also eliminate door rattling at high vehicle speeds.

1. With connecting rods in position after paragraphs B4 and B5, it is necessary to shorten each connecting rod by rotating each rod a maximum of two (2) turns. When turning, observe and make sure that the door panels are moving outwardly at the trailing edge and tightening against the door post seal.

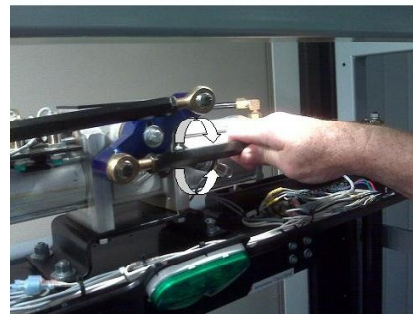

**NOTE:** Make sure that Preload does not prevent the door engine from reaching its full closed position. Proper preload will produce a door that is firmly closed against the jamb seals and is resistant to moderate pulling on the trailing edge while providing a firm open position for use as a hand hold support by an entering or exiting passenger.

## Adjustment Procedures: The Vapor Conventional and the Activair® Differential Engines

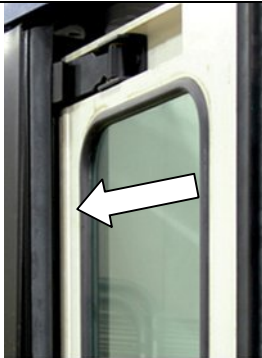

Before



After

2. Check for proper closing by first opening doors and then closing; observe the leading edges when meeting at the center. Rear (#2) door panel should lead the front (#1) door panel when closing. If the rear (#2) door panel does not lead, lengthen the front door panel connecting rod until the rear door panel leads with no butting or touching as the edges overlap at the center.

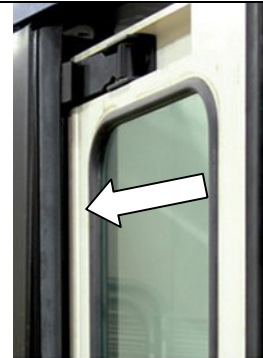

Before



After

2. Check for proper closing by first opening doors and then closing; observe the leading edges when meeting at the center. Rear (#2) door panel should lead the front (#1) door panel when closing. If the rear (#2) door panel does not lead, lengthen the front door panel connecting rod until the rear door panel leads with no butting or touching as the edges overlap at the center.

## Adjustment Procedures: The Vapor Conventional and the Activair® Differential Engines

### Correct Door Panel Closure

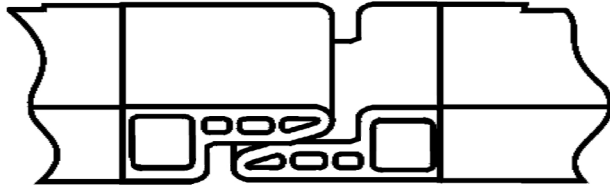

Front (#1) Door Panel

Rear (#2) Door Panel

### Incorrect Door Panel Closure

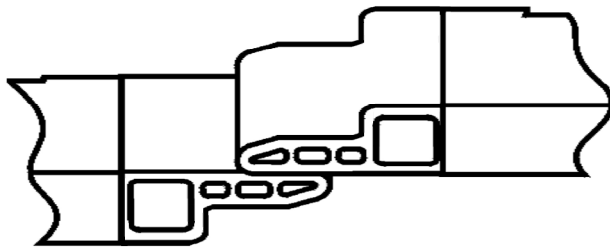

3. **CAUTION:** If the connecting rods are correctly adjusted, the teeter lever should be approximately 15° from fully horizontal when the doors are fully closed. It is extremely important that preloading not prevent the piston from bottoming against the center casting. The extra rotation will take up all the clearances in the linkage. In no case should an adjustment be made where the piston does not bottom in the door closed position.
4. Open the doors and make certain that they press against the door jamb before the engine pistons bottoms.

### D. Final Adjustments

1. Before locking down, observe the spherical rod end bearings. They should be aligned at 90° on their pins and rock freely to utilize their self-alignment feature.

### Correct Door Panel Closure

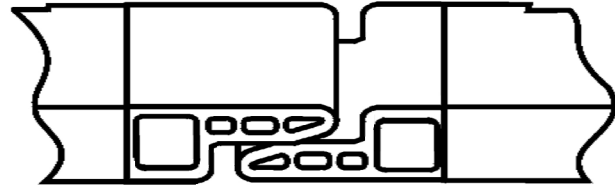

Front (#1) Door Panel

Rear (#2) Door Panel

### Incorrect Door Panel Closure

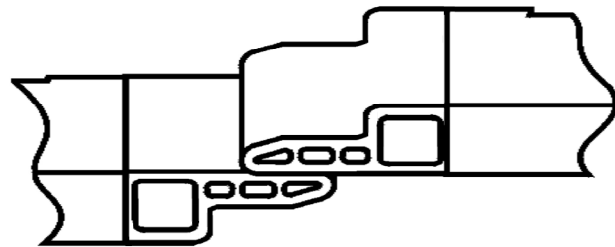

3. **CAUTION:** If the connecting rods are correctly adjusted, the teeter lever should be approximately 15° from fully horizontal when the doors are fully closed. It is extremely important that preloading not prevent the piston from bottoming against the center casting. The extra rotation will take up all the clearances in the linkage. In no case should an adjustment be made where the piston does not bottom in the door closed position.
4. Open the doors and make certain that they press against the door jamb before the engine pistons bottoms.

### D. Final Adjustments

1. Before locking down, observe the spherical rod end bearings. They should be aligned at 90° on their pins and rock freely to utilize their self-alignment feature.

## Adjustment Procedures: The Vapor Conventional and the Activair® Differential Engines

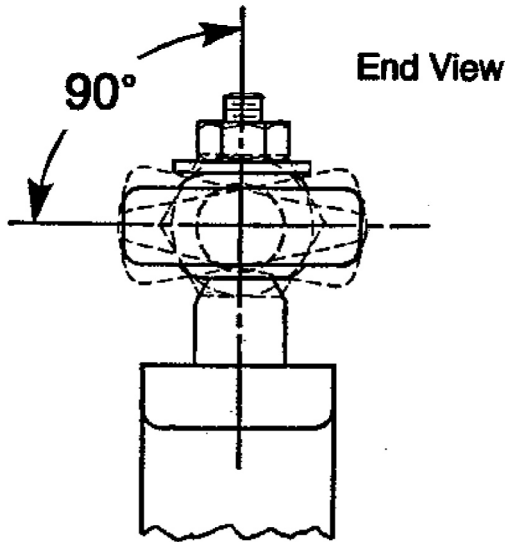

2. With the above aligned, firmly tighten the lock nuts against the connecting rod surface at each end.

### E. Pneumatic Adjustments

**WARNING:** Speed and cushion adjustment screws are not captive and may become projectiles if adjusted too far counterclockwise with air pressure applied to the door engine.

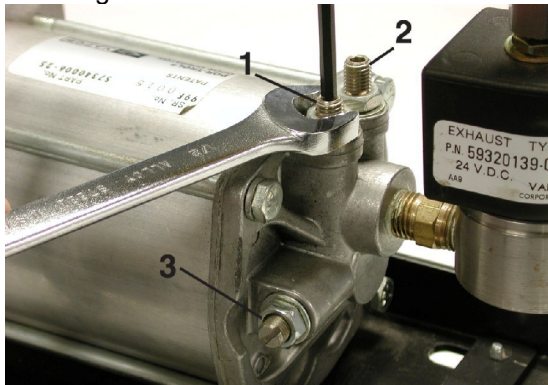

1. Door Closing Speed
2. Door Open speed
3. Open Cushion speed

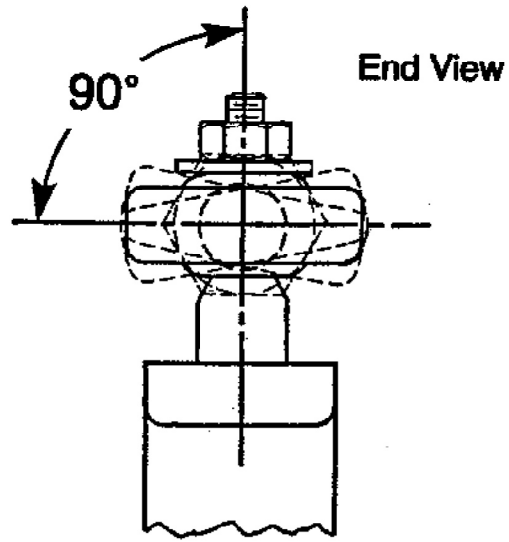

2. With the above aligned, firmly tighten the lock nuts against the connecting rod surface at each end.

### E. Pneumatic Adjustments

**WARNING:** Do not remove retainer plate (5) or speed, cushion and cushion onset adjustment screws become non-captive and may become projectiles if adjusted too far counterclockwise with air pressure applied to the door engine.



1. Door Closing Speed
2. Door Open speed
3. Open Cushion speed
4. Cushion Onset Adjustment
5. Retaining Plate Keeps Screws "Captive"

## Adjustment Procedures: The Vapor Conventional and the Activair® Differential Engines

1. First: Adjust closing speed (1) for satisfactory speed. **NOTE:** Loosen the jam nut and back screw out to increase speed.
2. Second: Adjust the opening speed (2) for satisfactory speed. **NOTE:** Loosen jam nut and back screw out to increase speed. Disregard slamming against jamb.
3. Third: Adjust the cushioning screw (3) to eliminate door opening slamming. **NOTE:** Loosen the jam nut and turn screw clockwise for more cushion effect and counterclockwise for less cushion effect. If necessary, readjust opening speed after adjusting the cushion screw. Proper cushion adjustment should provide smooth door open motion without slamming or hesitation at the cushion point. The point at which cushion begins is not adjustable with the Conventional Vapor Differential Engine.

**Recommendation:**

*Door speeds are adjustable but Industry Guidelines recommend that door edge speeds be no greater than 18 inches per second when opening and 12 inches per second when closing.*

1. First: Turning thumb screw (1), adjust closing speed for satisfactory speed. **NOTE:** This is now a finger adjustment and **no jam nut or tools are required.** Clockwise decreases speed and counterclockwise increases speed.
2. Second: Adjust the opening speed for satisfactory speed. **NOTE:** This is now a finger adjustment and **no jam nut or tools are required.** Clockwise decreases speed while counterclockwise increases speed. Disregard slamming against jamb.
3. Third: Adjust the cushioning screw to eliminate door opening slamming. **NOTE:** This is now a finger adjustment and **no jam nut or tools are required.** Clockwise increases cushion effect while counterclockwise decreases cushion effect. If necessary, readjust opening speed after adjusting the cushion screw. Proper cushion adjustment should provide smooth door open motion without slamming or hesitation at the cushion point.

**Additional Feature of Activair Differential Engine**

The onset of the cushion effect can be adjusted to the specific door opening to optimize door speed, while eliminating the slam upon open.

4. Fourth: Adjust the cushion onset screw with a ½ inch nut driver to set the optimum cushion onset point. The proper onset point is as close as possible to the door full open position while still eliminating slamming. Cushion onset is adjusted clockwise to begin the cushion effect earlier in the door open cycle and counterclockwise to begin the cushion effect later in the door cycle.

**Recommendation:**

*Door speeds are adjustable but Industry Guidelines recommend that door edge speeds be no greater than 18 inches per second when opening and 12 inches per second when closing.*

## Adjustment Procedures: The Vapor Conventional and the Activair® Differential Engines

### F. Electrical Adjustment

If mechanical switches are used, they will actuate in either the door closed or door open positions by the cam lobes on the teeter lever. Loosen the switch mounting screws to position switch for proper actuation

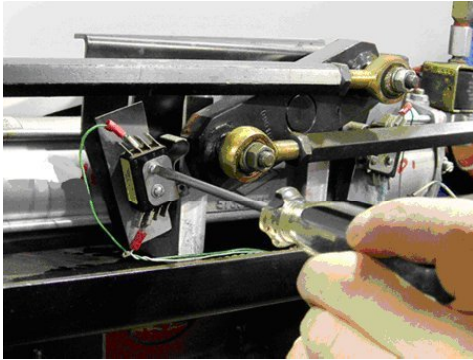

1. Proper adjustment must provide for a minimum of .015" of over-travel after actuation (over-travel is the movement allowed in the switch after actuation before the switch lever and plunger bottoms). Verify proper over travel using a .015" feeler gage between a bottomed switch and the teeter lever in the actuated position.



### F. Electrical Adjustment

**Note: Non-contact Proximity sensors are standard on the Activair differential engine. Sensors are equipped with LED indicators on the wire end of the sensor providing visual indication of actuation point. The door closed sensor is pre-adjusted by Vapor and requires no further customer adjustment. (See repair section below for door closed sensor position)**

1. Door open sensor adjustment should be set to actuate within 5° of the fully open position after door mechanical adjustments have been completed as described above. The actuation point of the sensor can be determined by observing the LED on the wire end of the sensor. The sensor should be positioned to provide a .08" ± .05" gap between the end of the teeter lever and the face of the sensor in the actuated position. Use a .08" feeler gage to verify proper gap.

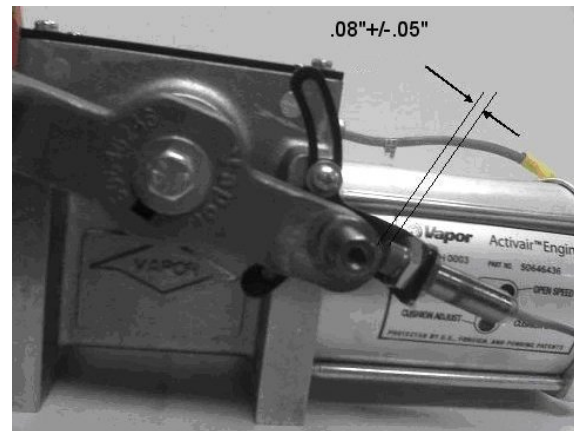

2. Cycle the door engine to check that sensors actuate and deactivate properly. Door open and closed sensors should actuate before the teeter lever is 5° from the full open and full closed positions. Sensor adjustment should be made after all mechanical and speed adjustments have been completed.

## Adjustment Procedures: The Vapor Conventional and the Activair® Differential Engines

2. Cycle the door engine to check that switches actuate and deactivate properly. Door open and closed switches should actuate before the teeter lever is 5° from the full open and full closed positions. All switch adjustments are to be performed after mechanical and speed adjustments have been completed.

### Alternate Mechanical Switch Configuration



Door Closed Switch to Actuate <math><5^\circ</math> from Full Closed Position



Door Open Switch to Actuate <math><5^\circ</math> from Full Open Position

Switch over-travel is controlled by the switch bracket in this configuration. The switch actuation point is adjusted by moving each switch laterally to get required actuation point as shown above.

### G. Door Closed Sensor Position (Replacement Only)

Should the door closed sensor require replacement, proceed as follows:

1. Remove the cover from the top of the center housing of the engine.
2. Remove and replace the door closed sensor.
3. While insuring that the sensor does not contact the internal target on the gear, rotate the door engine to the fully closed position.
4. Set the gap between the sensor face and the internal target to  $.08'' \pm .05''$ .
5. Lock sensor securely in place with the jam nuts provided.
6. Reassemble the cover to the center housing of the engine.
7. Check proper sensor function at the door closed position.





---

### (Activair Option)

### G. Optional Lock Sensor Adjustments

Note: All three lock sensors should be set to a gap of  $.08'' \pm .05''$  from their respective targets for proper actuation. Use a  $.08''$  feeler gage to verify proper gap.

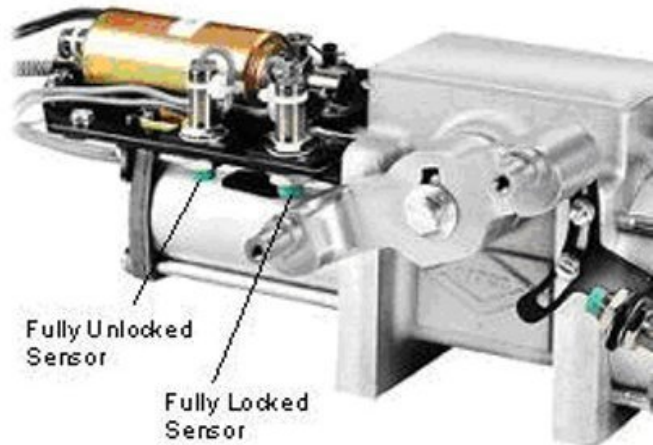
## Adjustment Procedures: The Vapor Conventional and the Activair® Differential Engines



1. The door fully locked sensor should deactivate when the locking pin is .012" from fully disengaged from the internal locking cam. (This can be verified by turning the teeter lever towards the open position while the air pressure is removed from the door engine.)
2. The fully unlocked sensor should be actuated within .08" of the fully unlocked position as defined by the position of the fully energized unlock solenoid.

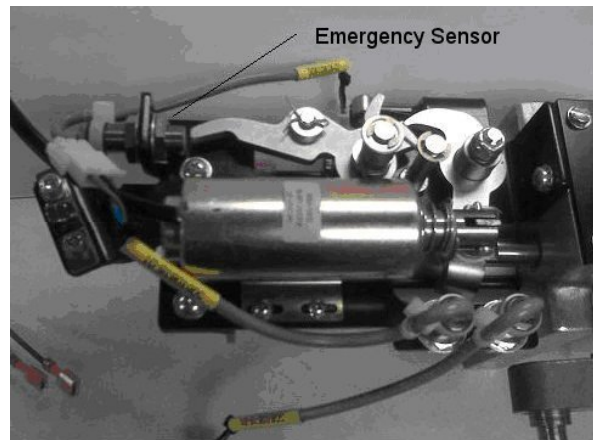

3. The emergency sensor should not actuate until the emergency cable is pulled and the emergency latching mechanism is engaged.