



Vapor **ADVANTAGE**

SAFETY • SYSTEMS • SERVICES • SOLUTIONS

Bulletin No. 603

June 2006

Door System Glossary

The **VAPOR ADVANTAGE** is a periodic discussion of topics concerned with the maintenance of passenger door systems for buses and related vehicles. We invite your comments and suggestions. Please e-mail them to vaporbusinfo@wabtec.com.

PRE-LOAD? All fields have their own jargon and transit bus door systems are no exception. While those who work regularly with door equipment may have a general understanding of door operating concepts and terminology, others may struggle with the “lingo”. Even individuals with years of experience with door systems may identify parts differently from others, as some parts and functions are known by several names.

To provide a better understanding of door concepts and terminology, Vapor has produced the attached **Bulletin #1001, “Door Systems Glossary and Part Identification”**. The bulletin contains a glossary of door system terms and briefly describes door system configurations (geometries). It also includes diagrams that identify primary door components. While this may be a review for many of our readers, most will find at least a word or two that they can’t define in their sleep. If we’ve omitted a word for which you need a definition, drop us an email and we’ll try to help. And we’ll include it in the next edition of the glossary.

► **VAPOR REPLACEMENT PARTS** Vapor Bus International designs, tests and qualifies its door systems to meet your requirements for safety, reliability and efficiency. Our qualification process includes the individual components as well as the integrated system. This rigorous process is necessary to achieve the day-in and day-out performance in revenue service that is the foundation of our reputation.

Genuine Vapor Parts are available from your bus manufacturer’s aftermarket organization or directly from Vapor Bus International by contacting our Customer Service Department.

► **TECHNICAL SUPPORT** Vapor Bus International now offers technical support via toll-free telephone or e-mail. Assistance in identifying a particular part, locating an adjustment or overhaul procedure, or trouble-shooting a problem is available Monday thru Friday from 8:00 am to 4:00 pm Central time. Messages left outside of business hours will be answered the next business day.

Toll Free Telephone: 1-866-375-4126

e-mail: techsupport@vapordoors.com

Request additional copies of the enclosed bulletin from Technical Support.

► **EXPERIENCED ADVICE** Vapor Sales Engineers can assist you with door system specifications and maintenance, overhaul and upgrade programs, and Vapor’s unit exchange and upgrade services.

Safety, Systems, Services, Solutions. Call us, we’re ready to serve you.

John Condon – Sales Mgr. – WEST 209-603-5189

Peter Buckley – Sales Mgr. – CENTRAL 847-226-8102

Mike O’Neill – Sales Mgr. – EAST 847-224-5087



This bulletin provides bus maintenance and engineering personnel with information on bus door system configurations, parts identification and terminology. It includes diagrams and descriptions of door system configurations ("Door Geometries"), component identification diagrams for the most common heavy transit bus door systems, and a glossary of North American door system terms.

Door Geometries

North American heavy transit buses are usually equipped with one or more of five different door system configurations ("Door Geometries"). Two of these five configurations, the Slide-Glide and the Swing, are by far the most widely used. This section includes diagrams and brief descriptions of each of the five geometries.

Slide-Glide

As the doors open, the panels rotate approximately 90° to a position perpendicular to the side of the vehicle and as close as possible to the door jamb. Panels can be contoured to match the body shape. Functions best in a rectangular opening.

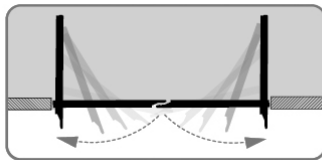

Swing

The door panels open by swinging outward to a position perpendicular to the side of the vehicle. Door panels extend away from the vehicle and must be flat.

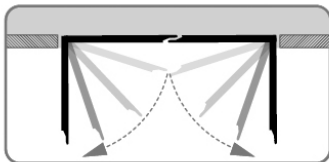

Parallelogram Plug

The opening doors rotate in a circular path from the closed position to an open position adjacent to the vehicle body and largely clear of the door opening. Panels can be curved to match the body contour. Can be configured for non-rectangular openings.

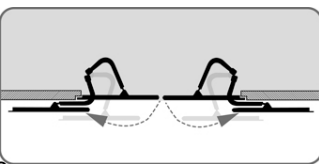

Bi-Fold

Each door leaf consists of two panels hinged together. On opening, the trailing edges of the door leaf assemblies rotate to draw the folding panels towards the door jambs. The panel assemblies rotate either into the door opening or out of the door opening (preferred). The door panels must be flat and the glazing area is limited.

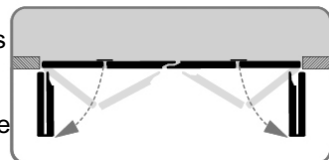

Outside Sliding Plug

The opening panels first move perpendicularly out from the door opening and then slide to an open position adjacent and parallel to the vehicle body. The panels may be contoured to match the vehicle body. Requires a complex actuating mechanism.

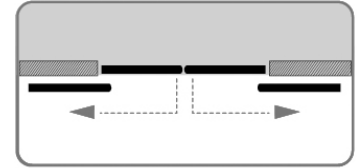

Component Identification

This section provides diagrams of Slide-Glide and Swing door systems with identification callouts for the major components.

Slide Glide Door System

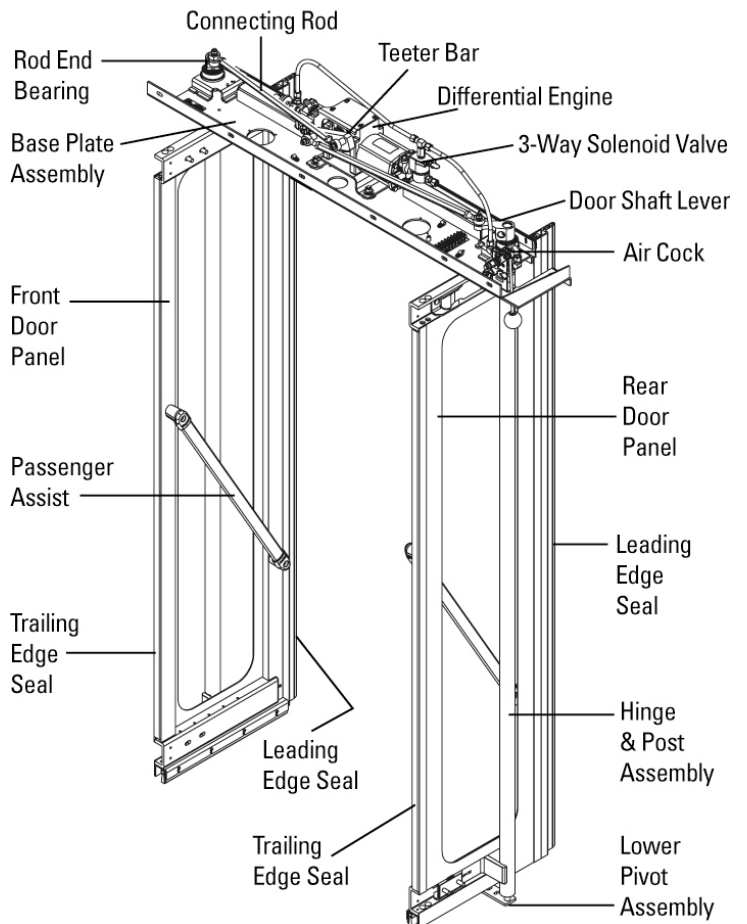

Swing Door System

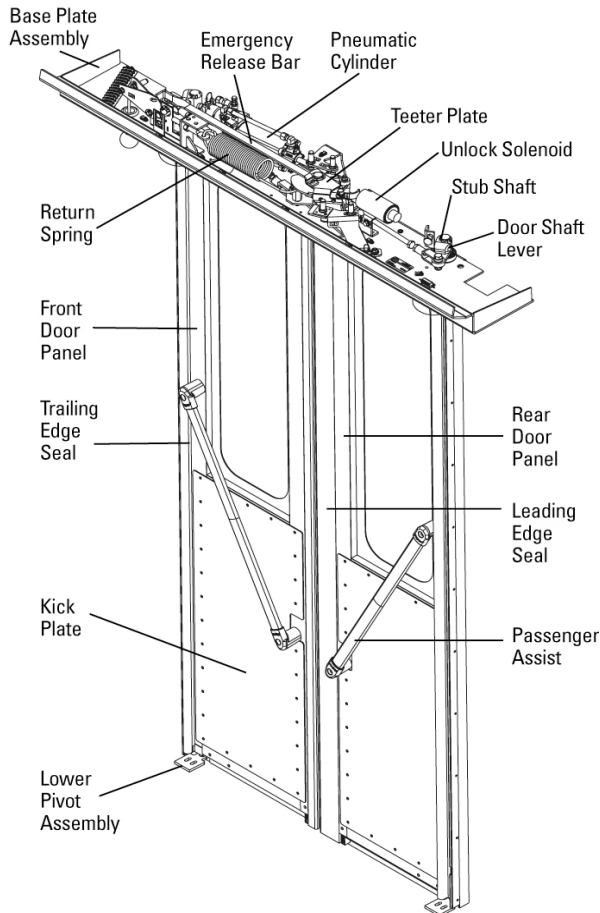

Glossary of Door System Terms

This section defines the terms commonly used in connection with bus door systems in North America. In some cases, different terms are used in other parts of the world.

Accelerator Interlock Device that blocks actuation of the vehicle accelerator when a passenger door is enabled and/or open.

Air Cock Three way valve with isolated ports used to isolate downstream components from the vehicle compressed air supply and to exhaust air from those components. Used as a component of door system emergency release provisions.

Air Open Spring Close (AOSC) A door operating mechanism wherein the doors are mechanically latched in the closed position, unlatched by the vehicle operator enabling the door, opened by an air cylinder activated by a passenger actuation device, and closed by an integral return spring, with speed controlled by metering the exhaust rate of the cylinder.

Base Plate Assembly An assembly incorporating the door actuation mechanism, door shaft bearings, door linkage elements, door control elements and accessories, all mounted on a metal plate, intended to be mounted above the door opening. The base plate assembly may form the door

header and may, in the case of slide-glide or bi-fold doors, incorporate the door guide tracks or rods.

Bi-Fold Door A door geometry in which each door leaf assembly consists of two door panels joined by a hinge or hinges. The leading edge of each door leaf assembly is affixed to a guide device that is constrained by a fixed track or rod mounted to the door header. The trailing edge is affixed to a vertical shaft connected to the actuation mechanism that supports the mass of the door. When the actuation mechanism rotates the shaft, the hinged panels move either into the vehicle ("inward bi-fold") or away from the vehicle ("outward bi-fold"). As the two door leaves rotate, the leading edge of the assembly is drawn away from the center of the door opening towards the door jamb, opening the door. Typically, two bi-fold door leaf assemblies are used in a door portal, one each opening to the right and left sides, respectively, of the door opening.

Bi-Parting Door A door arrangement consisting of two door panels or door leaf assemblies that move away from the centerline of the door opening to open the door.

Brake Interlock A system that provides partial application of the vehicle brakes when a passenger door is enabled and/or open.

CLASS™ (Contact-Less Acoustic Sensing System) A Vapor Bus International product that uses ultrasound technology to sense passengers and other objects in selected spaces near a door opening and provide passenger door actuation, hold open, sensitive edge enhancement, and detection of passengers in close proximity to the door when the bus is in motion. (See Drunk Alarm)

Connecting Rod A door linkage element that connects the door actuator prime mover to the door shaft via a door shaft lever.

Cushioning A function incorporated into the door actuator to slow the motion of the door panels as they approach the fully-open position.

Differential Engine A pneumatic prime mover for door systems in which two connected pistons moving within cylinders of different diameters drive an output shaft that provides rotary motion to actuate the doors. The differential engine is controlled by a single three-way poppet-type valve and may be arranged to provide optimum force-speed curves for door operation. The differential engine inherently resists door slamming if the door is held or if air pressure is suddenly increased.

Door Panel The actual physical element providing the door closure. May be fabricated from metal or a combination of metal and other materials, and typically incorporates one or more windows.

Door Geometry The physical arrangement of elements attaching the door panels to the vehicle and to the actuation and guiding mechanisms. The Door Geometry defines the motion of the door panels as they open and close.

Door Shaft Lever A crank arm that converts the liner motion of the connecting rod to rotary motion to drive the door shaft. Typically incorporates a square, hex or splined socket to synchronize door motion.

Door Timing Refers to the synchronization of the motion of the two door panels to assure proper seal alignment when the door panels are in the closed position.

Double Acting Cylinder A pneumatic prime mover consisting of a single piston moving within a single cylinder. The cylinder incorporates provisions for admitting air to and exhausting air from either side of the piston, resulting in piston motion in either direction.

Driver Controlled Door A passenger door for which the opening and closing functions are under the complete control of the vehicle driver.

Driver Enabled/Passenger Controlled Door A door for which the driver enables the opening function and the passenger actuates opening by pushing the door open or actuating a device such as a touch bar, touch tape or contact-less sensing system.

Driver's Door Controller A device located in the operator's compartment used to open and/or enable or close the vehicle's passenger doors. May be pneumatic, electric or hybrid pneumatic-electric.

Drunk Alarm (Colloquial) A safety system applied to a door opening outside of the driver's direct line of sight that triggers an alarm or a voice announcement when a passenger leans against one or both door panels while the bus is in motion.

Dwell Time In passenger transportation operations, the time elapsed from vehicle arrival at a stop to when it is ready for departure. Includes the time required for door opening, passenger deboarding and boarding, door closing, and interlock release.

Glazing Solid transparent material in a vehicle door or vehicle window. May be glass or plastic. In the United States and Canada, motor vehicle glazing may be subject to specific regulatory or consensus standards.

Glazing Rubber Elastomeric material that retains and seals the glazing to the door or window frame. In the United States and Canada, motor vehicle glazing rubber may be subject to specific regulatory or consensus standards.

Guide Rod A non-actuating connecting rod used with parallelogram plug doors to form one leg of the parallelogram linkage between the door panel and the vehicle body.

Hinge & Post Assembly Linkage element used in a slide-glide door system consisting of a vertical shaft with a stub shaft at its upper end and two hinge arms mounted perpendicular to the shaft axis. The circumferential location of the hinge arms is fixed relative to the location of the stub shaft positioning elements. The mass of the hinge & post assembly and the attached door panel are typically supported by the overhead door actuator. A non load bearing pivot locates the bottom of the shaft relative to the door opening (also referred to as shaft and arm assembly).

Leading Edge The edge of a door panel located adjacent to the vertical centerline of the door way in the closed position.

Limit Switch A mechanical or electronic switching device used in door systems to indicate door status or position. Switch designations commonly used on Vapor Bus International bus door systems are summarized below.

Switch Designation	Indication
LS1	Door Fully Closed (Used with Accelerator and Brake interlocks)
LS2	Door Fully Unlocked (Used on spring return doors with unlock solenoid)

LS3	Door Fully Open
LS4	Emergency Door Release Actuated
LS5	Door motion detection for "Drunk Alarm" based upon door motion
CSA or CSC	Door Closed (Old nomenclature. Not used on new product)
CSB or CSD	Door Open (Old nomenclature. Not used on new product)

Lock Pawl A component of an Air-Open Spring-Close or Push-Open Spring-Close door actuator that engages a slot in the teeter plate assembly to latch the door actuator mechanism in the doors closed position.

Outside Sliding Plug Door (OSSP) A door geometry wherein the opening panels first move perpendicularly out from the opening and then slide transversely from the doorway centerline to an open position adjacent and parallel to the vehicle body. The door panels are typically supported from the top by a hanger mechanism attached to the door actuator and constrained by a guide arm located near the bottom of the door jamb that is connected to a track near the bottom edge of the door panel.

Parallelogram Plug Door A door geometry in which each door panel is supported by curved (boomerang) arms attached to a vertical rotating door shaft mounted inside the vehicle body adjacent to the door jamb. A guide arm is attached between a point near the leading edge of the door panel and a point on the vehicle body. When the door actuator rotates the door shaft, the door panel moves out of the opening and follows a circular path to a point adjacent to the vehicle body and clear of the door opening. Parallelogram Plug Doors may be used in either single panel or bi-parting configurations.

Preload Force applied to a door panel by the door actuating mechanism to stabilize the panel in the fully open and fully closed positions. The preload provides a firm support for boarding or deboarding passengers in the open position and resists door panel rattling or fluttering in the closed position. The preload force is over and above that required to merely maintain the door panel to the fully open or fully closed positions.

Pressure Wave Switch An electrical switch device used to sense an air pressure pulse in an air wave sensitive edge system. The switch is normally open and closes for a brief period when a pressure wave is sensed.

Push Open Spring Close (POSC) A door operating mechanism wherein the doors are mechanically latched in the closed position, unlatched by the vehicle operator enabling the door, opened by a passenger pushing on the door panels, and closed by an integral spring, with speed controlled by metering the exhaust rate of the cylinder.

Return Spring An extension spring used with a Spring-Close door actuator to return the door panels the closed position after opening.

Rod End Bearing A device used to connect a drive rod to a post or stud. The device permits rotational motion of the post relative to the rod and corrects for moderate misalignment of the rod relative to the stud.

Roller Bracket Assembly An assembly consisting of a bracket with a shaft that is relatively parallel to the mounting face of the bracket. A cylindrical elastomeric roller is mounted on the shaft. Used as the guide device for the top leading edge of a slide-glide or bi-fold door panel.

Roller Channel A vertical channel in the underside of the door header which guides the roller on the roller bracket assembly. The channel may be mounted below the door header or recessed into the door header.

Sensitive Edge A door panel leading edge seal that includes a function to sense contact with obstructions in the path of the closing door. The sensitive edge may incorporate a mechanical switch device, air pressure wave sensing, or other technologies.

Shaft and Arm Assembly Linkage element used in a slide-glide door system consisting of a vertical shaft with a stub shaft at its upper end and two arms mounted perpendicularly to the shaft axis. The circumferential location of the arms is fixed relative to the location of the stub shaft positioning elements. The mass of the shaft and arm assembly and the attached door panel are typically supported by the overhead door actuator. A non load bearing pivot locates the bottom of the shaft relative to the door opening.

Shaft and Boomerang Assembly Linkage element used in a parallelogram plug door system consisting of a vertical shaft with a stub shaft at its upper end and two curved arms (boomerangs) mounted perpendicularly to the shaft axis. The circumferential location of the arms is fixed relative to the location of the stub shaft positioning elements. The mass of the shaft and arm assembly and the attached door panel are typically supported by the overhead door actuator. A non load bearing pivot locates the bottom of the shaft relative to the door opening.

Single Acting Cylinder A pneumatic prime mover consisting of a single piston moving within a single cylinder. The cylinder incorporates provisions for admitting air to and exhausting air from one side of the piston, driving the piston in one direction. The piston is typically moved in the opposite direction by an external or internal return spring.

Slide-Glide Door A door geometry in which the mass of the door panel is supported by a vertical shaft (post) located near the door jamb and connected to the top and bottom of the door panel near the trailing edge by means of arms or hinges. The door panel is constrained by a guide device affixed near the leading edge and connected to a fixed track or rod mounted to the door header. When the door actuating mechanism rotates the door shaft, the trailing edge of the door panel rotates into the vehicle, while the guide device constrains the leading edge to travel toward the door jamb to the open position. In the open position, the door panel is perpendicular to the side of the vehicle and as close as possible to the door jamb. The leading edge of the door panel may protrude beyond the vehicle side in the open position.

Stub Shaft A relatively short cylindrical shaft, one end of which has a section (square, hex or splined) that matches the socket on the door shaft lever and the other end has a round or square section that is affixed to a door panel or shaft and arm or hinge & post assembly. The positioning of the splined section relative to the door panel or shaft assembly is critical in assuring the proper synchronization of door panel motion.

Swing Door A door geometry in which the mass of the door panel is supported by means of a short vertical shaft (stub shaft) attached to the top trailing edge of the panel and connected to the door actuator. The bottom trailing edge of the door panel is positioned by a pivot arrangement attached to the vehicle floor. When the door actuator rotates the top shaft, the door panel rotates about an axis through its trailing edge to a point where the panel is perpendicular to the side of the vehicle. In the open position, most of the door panel is outside of the vehicle.

Teeter Bar (also Teeter Plate) A rotating element of the door actuator linkage containing two vertical pins to which the driven ends of the connecting rods are attached. The mounting radius of the pins in conjunction with the radius of the door shaft levers determines angular rotation range of the door panels while their relative rotational positions determine the angular synchronization of the door panels. When the door actuator prime mover is a pneumatic differential engine, the teeter bar is mounted to the output shaft. In an Air-Open Spring-Close or Push-Open Spring-Close door actuator, the teeter plate is mounted to an independent shaft attached to the base plate.

Touch Bar A device that combines a passenger assist and a mechanical or electronic switch that is used as a passenger actuation device for passenger-actuated doors. Typically mounted on the leading edge of the door panel.

Touch Tape A relatively low profile mechanical switch available in variable lengths that is frequently used as a passenger actuation device for passenger-actuated doors. Typically mounted on the leading edge of the door panel.

Trailing Edge The edge of a door panel located adjacent to the door jamb in the closed position.

Unlock Solenoid An electric coil and plunger assembly used on Air-Open Spring-Close or Push-Open Spring-Close door actuators to unlatch the lock pawl from the teeter plate assembly.